

Interoperability Test Guideline
For Optical Access Network Devices

HATS Conference
(Promotion Conference of Harmonization of Advanced Telecommunication Systems)
Steering Committee

Interoperability Test Guideline For Optical Access Network Devices

Revision history

Version	Date of revision	Content of revision	Person in charge
1.0	2012/12/19	First edition	Nishihara, Takizawa, Onishi, Kusano
1.1	2013/5/23	Add clauses 4.3.2 and 4.4. Referenced SIEPON draft version is changed to D3.4.	Kouyama, Nishihara, Takizawa, Kusano
1.2	2013/12/27	Add clauses: 3,1,3 PON Protocol Analyzer 3,2,4 Test configuration with multiple ONUs, with the PON Protocol Analyzer 4.5 Group DE: Data Encryption and 4.6 Group MG: Management Update the APPENDIX OPTICAL ACCESS INTEROPERABILITY TEST RESULT	Kouyama, Takizawa, Kusano
1.3	2014/12/25	- Updated the organization name from Optical Access Ad-hoc to Optical Access Ad-hoc Test Implementation Liaison Committee and TILC as its abbreviation - In the subclause 2.1, removed D3.4 from the referencing SIEPON version - Unified mixed use of "IEEE P 1904.1" and "IEEE Std 1904.1" in to IEEE Std 1904.1 - In the subclause 4.7, updated referencing clause number to subclause 4.2 through 4.6 - Added PICS list in the APPENDIX OPTICAL ACCESS INTEROPERABILITY TEST RESULT	Onishi, Nakano, Takizawa, Kusano

All copyrights to this documentation are reserved by the HATS Conference.

This documentation may not be reproduced, copied, modified, diverted, or transmitted and delivered on the network, in whole or in part, without the permission of the HATS Conference.

Contents

REVISION HISTORY.....	2
1. BACKGROUND AND PURPOSE.....	6
1.1. Background.....	6
1.2. Purpose	6
1.3. Scope of interoperability test.....	6
2. PRECONDITIONS	7
2.1. Normative references.....	7
2.2. Pre-test	7
3. TEST EQUIPMENT AND TEST CONFIGURATION.....	8
3.1. Functional requirements for test equipment	8
3.1.1. Introduction.....	8
3.1.2. Packet Analyzer	8
3.1.3. PON Protocol Analyzer	8
3.1.4. Packet Generator	9
3.1.5. ODN	9
3.2. Test equipment configuration.....	10
3.2.1. Introduction.....	10
3.2.2. Test configuration with a single ONU, without the PON Protocol Analyzer	10
3.2.3. Test configuration with multiple ONUs, without the PON Protocol Analyzer	11
3.2.4. Test configuration with multiple ONUs, with the PON Protocol Analyzer.....	11
4. TESTS.....	13
4.1. Introduction.....	13

4.2.	Group DCD: Device and capability discovery	14
4.2.1.	Test case for eOAM and capability discovery process, successful discovery	14
4.3.	Group UVM/TVM: ONU/OLT VLAN mode	15
4.3.1.	Test case for UVM/TVM.....	15
4.3.2.	Test case for UVM/TVM, data transmission between OLT and multiple ONUs	19
4.4.	Group MC: Multicast connectivity	23
4.4.1.	Test case for multicast connectivity, multicast data transmission	23
4.5.	Group DE: Data Encryption.....	26
4.5.1.	Test case for data encryption, successful IEEE Std 802.1ae-2006.....	26
4.6.	Group MG: Management	31
4.6.1.	Test case for management, successful eOAM sequence and message format.....	31
4.7.	Judgement	33
4.8.	Test result.....	34
5.	USE OF TEST RESULT	35
5.1.	Usage	35
5.2.	Feedback to standards.....	35
APPENDIX	OPTICAL ACCESS INTEROPERABILITY TEST RESULT	36
ATTACHMENT	TEST CONFIGURATIONS	40

1. Background and purpose

1.1. Background

IEEE Std 1904.1 (Service Interoperability in Ethernet PON) to be standardized by IEEE (Institute of Electrical and Electronics Engineers) specifies a set of protocols to be used for realizing interoperability between EPON Optical Line Terminator (OLT) and EPON Optical Network Unit (ONU). The protocol assures multivendor environment among systems which implement it. For the sound development of the technology, it is necessary to prove the feasibility of the technology and resolve potential interoperability issues to reflect the outcome to the standard.

1.2. Purpose

With the market share of the products based on the above standard growing, it is essential to ensure interoperability between the products in order to facilitate utilization of EPON-based optical access system. In EPON history, the IEEE Std 1904.1 (SIEPON) is the very first attempt to support interoperable protocol between OLT and ONU for system-level functionality. Therefore, it is highly expected to confirm that the specification can properly and sufficiently be supported among systems to perform the requested functions in the implementation. To understand the maturity of systems in terms of alignment with the standard, it is desired to execute interoperability test among systems.

This guideline provides procedures to conduct the test which checks the specified interoperability between the devices manufactured by different suppliers.

The specific interoperability tests are conducted by the Optical Access Test Implementation Liaison Committee (TILC) of HATS Conference administered by the Communication and Information network Association of Japan (CIAJ). These tests not only confirm interoperability between each product but also it is expected to improve a maturity of system level EPON interoperability in practice.

1.3. Scope of interoperability test

The scope defined by this guideline is the interoperability between equipment compliant with the IEEE Std 1904.1 specification in a multi-vendor environment. This guideline is principally aligned with IEEE Std 1904.1 Conformance02 which specifies the conformance test for one of the function packages, so called package B, defined in the IEEE Std 1904.1. This guideline provides a minimum necessary procedure for the interconnectivity test environment. Additional function tests may be added in the future according to necessity and demand.

2. Preconditions

2.1. Normative references

The following referenced documents are indispensable for the application of the standard to be complied for the interoperability test (i.e., they must be understood and used, so each referenced document is cited in text and its relationship to this document is explained). For dated references, only the edition cited applies. For undated references, the latest edition of the referenced document (including any amendments or corrigenda) applies.

IEEE Std 1904.1™ Standard for Service Interoperability in Ethernet Passive Optical Networks (SIEPON)

2.2. Pre-test

Prior to attending the interoperability test, each participant is requested to conduct a test described in this test guideline using devices at his/her own control and confirm normality which means be able to pass all tests with owning devices and test environment.

3. Test equipment and test configuration

3.1. Functional requirements for test equipment

3.1.1. Introduction

This subclause provides definitions of the critical elements of the conformance test setup, namely the Packet Analyzer, Packet Generator, and ODN, which are connected together as defined in more detail in 3.2.

Individual devices are specified in terms of functional requirements and do not impose specific implementation. For test purposes, functions of two or more device described in the following subclause may be combined into a single functional device, as long as the new functional device meets all the requirements outlined below, when connected in the conformance test configuration defined in 3.2.

3.1.2. Packet Analyzer

The Packet Analyzer is a device, which is connected to the OLT NNI and ONU UNI interfaces in a way defined in more details in 3.2, and supports the following functions:

- captures all packets transmitted by the OLT across the NNI interface towards the metro/aggregation network;
- captures all packets transmitted by the ONU across the UNI interface towards connected CPEs;
- examines the content of the captured OAMPDUs, as defined in IEEE Std 802.3, providing a way to list, display and examine content of individual fields in the captured packets.

3.1.3. PON Protocol Analyzer

The PON Protocol Analyzer is a device that is connected to the ODN as shown in 3.2, and that supports the following functions:

- Capture of upstream packets, including MPCPDUs, OAMPDUs, eOAMPDUs, and data frames, as specified in IEEE Std 802.3, and IEEE Std 1904.1, transmitted by any of the connected ONUs towards the OLT.
 - Capture of downstream packets, including MPCPDUs, OAMPDUs, eOAMPDUs, and data frames, as specified in IEEE Std 802.3, and IEEE Std 1904.1, transmitted by the OLT towards any of the connected ONUs.
 - Simultaneous capture of the downstream and upstream packets i.e., support at least two capture interfaces, one of which is configured to capture upstream packets and the other is configured to capture downstream packets.
-

- Analysis of the content of the captured packets, including a capability to examine and display/output the content of individual fields in the captured packets.

The PON Protocol Analyzer does not modify the content of any upstream or downstream packets. Additionally, when connected to the ODN, this device does not increase the channel insertion loss in a way that would cause it to exceed the maximum channel insertion loss value specified in 3.1.5.

3.1.4. Packet Generator

The Packet Generator is a device, which is connected to the OLT NNI and ONU UNI interfaces in a way defined in more details in 3.2, and supports the following functions:

- generates a pre-defined number of data packets of pre-configured type, meeting specific packet size distribution and type requirements, as configured on the device using the user interface;
- provides a user interface for configuration of the following (examples) parameters of the packet stream:
 - number of packets to be generated (specific number, continuous mode, burst mode etc.);
 - type(s) of packets to be generated (OAMPDU, MPCPDU, eOAMPDU, IPv4 packets, IPv6 packets etc.);
 - packet size distribution in case of IP packets, using a predefined or random packet size distribution;
- provides a user interface for configuration of specific packet types i.e. constriction of specific packet types based on configuration of specific fields in the packet through assignment of user-provided values to such fields as EtherType, Size, Payload, VLANs etc.

The Packet Generator is not connected to the ODN and does not influence the loss observed between the OLT_MDI and ONU_MDI interfaces. This device may be connected to the OLT NNI and ONU UNI via copper or fiber links, depending on the interface types supported on the OLT and ONUs under test.

3.1.5. ODN

Testing conformance of the optical distribution network (ODN) with the respective IEEE Std 802.3 requirements is outside of the scope of this conformance plan. Various aspects of physical layer transmission e.g. target sensitivities, launch powers, immunity to dispersion etc. are not part of the conformance tests.

However, to guarantee smooth execution of any conformance tests described in this standard, a set of basic requirements regarding the ODN is needed to make sure that stable data link can be established between the OLT and ONUs. In this way, optimum operating conditions can be achieved, resulting in a minimum packet loss required by some of the tests.

The target channel insertion loss for the ODN used during the conformance tests under this standard is recommended to range between 15 dB and 20 dB. The ODN can be realized by connecting the splitter with either fiber cables of appropriate length or attenuators to achieve the minimum required channel insertion loss of 15 dB. The recommended split ratio for PS (see 3.2 for more details) is 2:16. The recommended maximum distance between the OLT and the furthest ONU is 20 km, to limit the observed signal dispersion. During the design of the ODN for conformance testing under this standard, the loss introduced by the PON Protocol Analyzer needs to be accounted for.

Special care should be taken to guarantee the minimum channel insertion loss for the ODN, especially in case of 10G-EPON devices subject to conformance tests. Specific requirements for the minimum channel insertion loss for specific PMDs can be found in IEEE Std 802.3, Clause 75 for 10G-EPON devices and Clause 60 for 1G-EPON devices.

3.2. Test equipment configuration

3.2.1. Introduction

This subclause outlines the common test configuration used by individual conformance test cases defined in Clause 4.

Individual test case covered in Clause 4 may specify their own modified test configurations, as needed, building from the generic test configurations defined in the following subclauses.

3.2.2. Test configuration with a single ONU, without the PON Protocol Analyzer

- (1) Use a dedicated private network which is isolated from a local area network used for general communication.
- (2) Figure 3-1 shows connections among components required for the test.

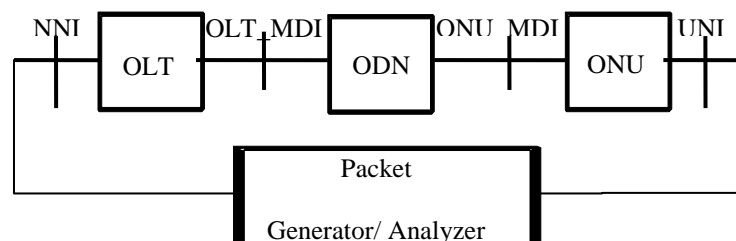

Figure 3-1— Test equipment configuration

3.2.3. Test configuration with multiple ONUs, without the PON Protocol Analyzer

- (1) Use a dedicated private network which is isolated from a local area network used for general communication.
- (2) Figure 3-2 shows connections among components required for the test.

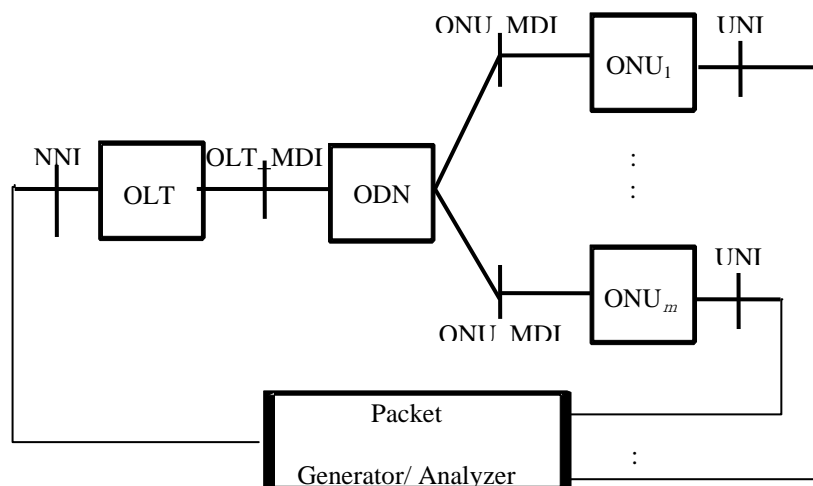

Figure 3-2 Test equipment configuration in the case with multiple ONUs

3.2.4. Test configuration with multiple ONUs, with the PON Protocol Analyzer

- (1) Use a dedicated private network which is isolated from a local area network used for general communication.
- (2) Figure 3-3 shows connections in case of using PON Protocol Analyzer.

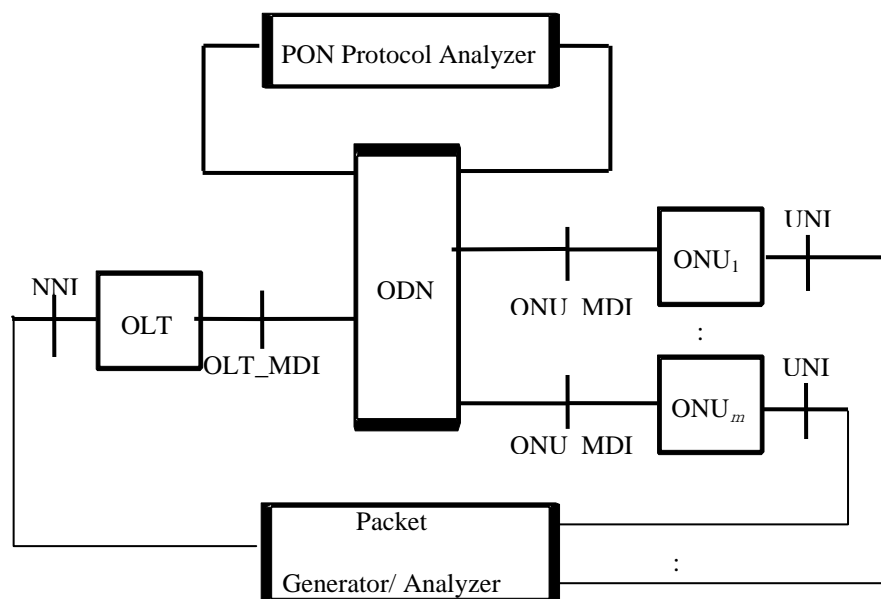

Figure 3-3 Test equipment configuration in the case with multiple ONUs, with PON Protocol Analyzer

4. Tests

This section consists from; general instruction in Section 4.1 and individual test cases in the followed by section from 4.2 and after.

4.1. Introduction

On the date arranged beforehand, the test must be conducted according to the procedures described in the Section 4.2 and after. It is requested to execute the test following to the listed order of the sections of test case descriptions.

The combination of the participants will be arranged in a round robin manner.

Note that the interoperability test between the products made by the same manufacturer is assumed to have been completed prior to the interoperability test and it is not included in the combination.

4.2. Group DCD: Device and capability discovery

4.2.1. Test case for eOAM and capability discovery process, successful discovery

This test case group covers verification of the interoperability for the negotiation flow between OLT and ONU to establish the data channel.

4.2.1.1. Required equipment and test configuration

Test configuration per 3.2.2 shall be used to complete this test case.

4.2.1.2. Test description

This test verifies DUTs compliance with;

- OAM discovery process defined in IEEE Std 1904.1, 12.2.2.1, including the sequence, format and values of *Information* OAMPDU generated by DUTs.

Specifically, the following conditions are tested:

- Successful completion of OAM discovery process with a correct *Local Information* TLV.

4.2.1.3. Test procedure and expected results

Start of Test

Step 1 Initial configuration and provisioning

- 1.1 Connect all equipment as defined in the test setup configuration per 4.2.1.1.
- 1.2 Power on DUTs, allow DUTs to complete IEEE Std 802.3 MPCP discovery process.

Step 2 Successful IEEE Std 802.3 Clause57 OAM discovery process

- 2.1 The OAM discovery process defined in IEEE Std 802.3, Clause 57 is executed.

Expected result 1: *The OAM discovery process shall succeed. OLT and ONU shall keep OAM link for 60 seconds.*

End of Test

4.3. Group UVM/TVM: ONU/OLT VLAN mode

4.3.1. Test case for UVM/TVM

This test case group covers verification of the interoperability for the data transmission associated with the following VLAN modes, as defined in IEEE Std 1904.1, 7.2.2.1, namely:

- ONU Tagging VLAN mode; and
- OLT Translation VLAN mode.

4.3.1.1. Required equipment and test configuration

Test configuration per 3.2.2 shall be used to complete this test case.

ONU with one or more UNIs is connected to the packet generator/analyzer. Individual ports are designated as UNI_x , where x corresponds to the port number, as reported by ONU. OLT is connected to the packet generator/analyzer via the NNI.

For the purpose of this test, ONU and OLT are configured to operate in the following configurations.

ONU configurations:

- Authentication: disabled
- Encryption: disabled
- VLAN mode: ONU Tagging VLAN mode
- VLAN based multicast filtering: disabled
- MAC address based multicast filtering: disabled

OLT configurations:

- Authentication: disabled
 - Encryption: disabled
 - VLAN mode: OLT Translation VLAN mode
 - VLAN based multicast filtering: disabled
 - MAC address based multicast filtering: disabled
-

The provisioning for ONU and OLT may use vendor-specific mechanisms and are outside the scope of this test case.

Both Authentication and Encryption are disabled for the ONU and the OLT, and are not tested in this test case. In this test, ONU and OLT do not perform authentication after the registration process and data transmission between ONU and OLT is realized as defined in IEEE Std 802.3 without encryption mechanism.

The packet generator is configured to generate flows of Ethernet frames with or without VLAN tags. The flows of Ethernet frames are shown in Table 4-1 for the upstream direction and in Table 4-2 for the downstream direction. Each flow consists of K packets (K=2000). The size of each Ethernet frame is 1000 octets. The order of frames belonging to different flows in the aggregated stream is not specified.

Table 4-1 Test flow in the upstream direction for packet generator

#	DA	SA ^a	VLAN0-VID
1	0x90-82-60-22-22-00	0x90-82-60-11-11-UNI _N	not present

^{a)} The lowest octet in the MAC is derived from the UNI_N number, represented in a 1 octet-wide format. For example, for UNI₁, the MAC is equal to 0x90-82-60-11-11-01, for UNI₂₁, the MAC is equal to 0x90-82-60-11-11-15.

Table 4-2 Test flow in the downstream direction for packet generator

#	DA ^b	SA	VLAN0-VID ^a
1	0x90-82-60-11-11-UNI _N	0x90-82-60-22-22-00	0x2-00

^{a)} The remaining fields in the VLAN0 tag shall use IEEE Std 802.1Q-compliant values (default values)

^{b)} The lowest octet in the MAC is derived from the UNI_N number, represented in a 1 octet-wide format. For example, for UNI₁, the MAC is equal to 0x90-82-60-11-11-01, for UNI₂₁, the MAC is equal to 0x90-82-60-11-11-15.

4.3.1.2. Test description

This test verifies the interoperability for the data transmission between ONU and OLT when configured in the specific VLAN modes. Specifically, the following conditions are tested:

- Interoperability for the upstream and downstream data transmission when ONU is operating in the ONU Tagging VLAN mode, and OLT is operating in the OLT Translation VLAN mode, per IEEE Std 1904.1, 7.2.2.1.

4.3.1.3. Test procedure and expected results

Start of Test

Step 1 Initial configuration and provisioning

- 1.1 Connect all equipment as defined in the test setup configuration per 4.3.1.1.
- 1.2 Configure the PON-VID value to 0x100 for ONU, as defined in IEEE Std 1904.1, 7.2.2.1.4. Configure the user-side VID value to 0x100 and the network-side VID value to 0x200 for the given LLID for OLT, as defined in IEEE Std 1904.1, 7.2.2.1.5.
- 1.3 Reboot ONU or connect the PON link between ONU and OLT to allow ONU to register at OLT.

Step 2 VLAN mode configuration tests, upstream direction

- 2.1 Start the packet analyzer. Start the packet generator in the upstream direction, transmitting the test flow per Table 4-1 simultaneously across each UNI_N on ONU towards NNI on OLT. Allow the packet generator to complete its data trace for all UNI_N .

Expected result 1: *Packet analyzer connected to NNI on OLT shall receive the following number and type of packets for each of frame flows from each UNI_N , as defined in Table 4-3:*

— K frames for each of frame flows per UNI on ONU.

Table 4-3— Packets received by the packet analyzer in the upstream direction

#	DA	SA ^b	VLAN0-VID ^a
1	0x90-82-60-22-22-00	0x90-82-60-11-11- UNI_N	0x2-00

^{a)} The remaining fields in the VLAN0 tag shall use IEEE Std 802.1Q-compliant values (default values)

^{b)} The lowest octet in the MAC is derived from the UNI_N number, represented in a 1 octet-wide format. For example, for UNI_1 , the MAC is equal to 0x90-82-60-11-11-01, for UNI_{21} , the MAC is equal to 0x90-82-60-11-11-15.

Step 3 VLAN mode configuration tests, downstream direction

- 3.1 Start the packet analyzer. Start the packet generator in the downstream direction, transmitting the test flow per Table 4-2 across NNI towards each UNI_N on ONU. Allow the packet generator to complete its data trace for all UNI_N .

Expected result 2: *Packet analyzer connected to each UNI_N on ONU shall receive the following number and type of packets for each of frame flows, as defined in Table 4-4:*

— K frames for each of frame flows per UNI on ONU.

Table 4-4— Packets received by the packet analyzer in the downstream direction

#	DA ^a	SA	VLAN0-VID
1	0x90-82-60-11-11- UNI_N	0x90-82-60-22-22-00	not present

^{a)} The lowest octet in the MAC is derived from the UNI_N number, represented in a 1 octet-wide format. For example, for UNI_1 , the MAC is equal to 0x90-82-60-11-11-01, for UNI_{21} , the MAC is equal to 0x90-82-60-11-11-15.

End of Test

4.3.2. Test case for UVM/TVM, data transmission between OLT and multiple ONUs

This test case covers verification of the interoperability for the data transmission in the case that multiple ONUs under test are connected to a single OLT.

In addition, this test case also covers verification of the interoperability for the data transmission associated with the following VLAN modes, as defined in IEEE Std 1904.1, 7.2.2.1, namely:

- ONU Tagging VLAN mode; and
- OLT Translation VLAN mode.

4.3.2.1. Required equipment and test configuration

Test configuration per 3.2.3 shall be used to complete this test case.

ONU_{*m*} with one or more UNIs is connected to the packet generator/analyzer via UNI_{*m,n(m)*}, where *m* indicates the ONU number, and *n(m)* corresponds to the UNI number in ONU_{*m*}, as reported by ONU. OLT is connected to the packet generator/analyzer via the NNI.

For the purpose of this test, ONUs and OLT are configured to operate in the following configurations.

ONU configurations:

- Authentication: disabled
- Encryption: disabled
- VLAN mode: ONU Tagging VLAN mode
- VLAN based multicast filtering: disabled
- MAC address based multicast filtering: disabled

OLT configurations:

- Authentication: disabled
 - Encryption: disabled
 - VLAN mode: OLT Translation VLAN mode
 - VLAN based multicast filtering: disabled
 - MAC address based multicast filtering: disabled
-

The provisioning for ONUs and OLT may use vendor-specific mechanisms and are outside the scope of this test case.

Both Authentication and Encryption are disabled for the ONUs and the OLT, and are not tested in this test case. In this test, ONUs and OLT do not perform authentication after the registration process and data transmission between multiple ONUs and OLT is realized as defined in IEEE Std 802.3 without encryption mechanism.

The packet generator is configured to generate flows of Ethernet frames with or without VLAN tags. The flows of Ethernet frames are shown in Table 4-5 for the upstream direction and in Table 4-6 for the downstream direction. Each test flow consists of K packets ($K=2000$). The size of each Ethernet frame is 1000 octets. The order of frames belonging to different flows in the aggregated stream is not specified.

Table 4-5 Test flow in the upstream direction for packet generator to UNI _{$m,n(m)$} on ONU _{m}

Test flow number	DA	SA ^a	VLAN0-VID
1	0x90-82-60-22-22-00	0x90-82-60-11-11-UNI _{$m,n(m)$}	not present

^{a)} The lowest octet in the MAC is derived from the UNI _{$m,n(m)$} number, represented in a 1 octet-wide format. For example, for UNI _{$m,1$} , the MAC is equal to 0x90-82-60-11-11-01, for UNI _{$m,21$} , the MAC is equal to 0x90-82-60-11-11-15.

Table 4-6 Test flows in the downstream direction for packet generator

Test flow number	DA ^{a,c}	SA	VLAN0-VID ^{a,b}
1	0x90-82-60-11-11-UNI _{$1,n(1)$}	0x90-82-60-22-22-00	0x2-01
2	0x90-82-60-11-11-UNI _{$2,n(2)$}	0x90-82-60-22-22-00	0x2-02
:	:	:	:
M	0x90-82-60-11-11-UNI _{$m,n(m)$}	0x90-82-60-22-22-00	0x2-ONU _{m}

^{a)} m represents ONU number.

^{b)} The remaining fields in the VLAN0 tag shall use IEEE Std 802.1Q-compliant values (default values). The lowest octet in the VLAN0 VID is derived from the ONU number, represented in a 1 octet-wide format.

^{c)} The lowest octet in the MAC is derived from the UNI _{$m,n(m)$} number, represented in a 1 octet-wide format. For example, for UNI _{$m,1$} , the MAC is equal to 0x90-82-60-11-11-01, for UNI _{$m,21$} , the MAC is equal to 0x90-82-60-11-11-15.

4.3.2.2. Test description

This test verifies the interoperability for the data transmission between OLT and multiple ONUs when configured in the specific VLAN modes. Specifically, the following conditions are tested:

- Interoperability for the upstream and downstream data transmission when ONUs are operating in the ONU Tagging VLAN mode, and OLT is operating in the OLT Translation VLAN mode, per IEEE Std 1904.1, 7.2.2.1.

4.3.2.3. Test procedure and expected results

Start of Test

Step 1 Initial configuration and provisioning

- 1.1 Connect all equipment as defined in the test setup configuration per 4.3.2.1.
- 1.2 Configure the PON-VID value to 0x100 for all ONUs under test, as defined in IEEE Std 1904.1, 7.2.2.1.4. For the OLT, configure the user-side VID value to 0x100 and the network-side VID value to 0x2-ONU_m for the ONU_m, as defined in IEEE Std 1904.1, 7.2.2.1.5.
- 1.3 Reboot ONUs or connect the PON link between ONUs and OLT to allow ONUs to register at OLT.

Step 2 VLAN mode configuration tests, upstream direction

- 2.1 Start the packet analyzer. Start the packet generator in the upstream direction, transmitting the test flows per Table 4-5 simultaneously across each UNI_{m,n(m)} on ONU_m towards NNI on OLT. Allow the packet generator to complete its data trace for all UNI_{m,n(m)}.

Expected result 1: *Packet analyzer connected to NNI on OLT shall receive the following number and type of packets for each of frame flows from each UNI_{m,n(m)} of ONU_m, as defined in Table 4-7:*

- *K frames for each of frame flows per UNI_{m,n(m)} of ONU_m.*

Table 4-7— Packets received by the packet analyzer in the upstream direction

Frame flow number	DA	SA ^{a,c}	VLAN0-VID ^{a,b}
1	0x90-82-60-22-22-00	0x90-82-60-11-11-UNI _{1,n(1)}	0x2-01
2	0x90-82-60-22-22-00	0x90-82-60-11-11-UNI _{2,n(2)}	0x2-02
:	:	:	:
M	0x90-82-60-22-22-00	0x90-82-60-11-11-UNI _{m,n(m)}	0x2-ONU _m

^{a)} m represents ONU number.

^{b)} The remaining fields in the VLAN0 tag shall use IEEE Std 802.1Q-compliant values (default values). The lowest octet in the VLAN0 VID is derived from the ONU number, represented in a 1 octet-wide format.

^{c)} The lowest octet in the MAC is derived from the UNI_{m,n(m)} number, represented in a 1 octet-wide format. For example, for UNI_{m,1}, the MAC is equal to 0x90-82-60-11-11-01, for UNI_{m,21}, the MAC is equal to 0x90-82-60-11-11-15.

Step 3 VLAN mode configuration tests, downstream direction

3.1 Start the packet analyzer. Start the packet generator in the downstream direction, transmitting the test flow per Table 4-6 across NNI towards each UNI_{m,n(m)} on ONU_m. Allow the packet generator to complete its data trace for all UNI_{m,n(m)}.

Expected result 2: *Packet analyzer connected to each UNI_{m,n(m)} on ONU_m shall receive the following number and type of packets for each of frame flows, as defined in Table 4-8:*

— K frames for each of frame flows per UNI_{m,n(m)} on ONU_m.

Table 4-8— Packets received by the packet analyzer in the downstream direction from UNI_{m,n(m)} on ONU_m

Frame flow number	DA ^a	SA	VLAN0-VID
1	0x90-82-60-11-11-UNI _{m,n(m)}	0x90-82-60-22-22-00	not present

^{a)} The lowest octet in the MAC is derived from the UNI_{m,n(m)} number, represented in a 1 octet-wide format. For example, for UNI_{m,1}, the MAC is equal to 0x90-82-60-11-11-01, for UNI_{m,21}, the MAC is equal to 0x90-82-60-11-11-15.

End of Test

4.4. Group MC: Multicast connectivity

This test case group covers verification of the interoperability for the multicast connectivity.

4.4.1. Test case for multicast connectivity, multicast data transmission

This test case covers verification of the interoperability for the multicast data transmission associated with the following VLAN modes, as defined in IEEE Std 1904.1, 7.2.2.1, namely:

- ONU Tagging VLAN mode; and
- OLT Translation VLAN mode.

4.4.1.1. Required equipment and test configuration

Test configuration per 3.2.3 shall be used to complete this test case.

ONU_{*m*} with one or more UNIs is connected to the packet generator/analyzer via UNI_{*m,n(m)*}, where *m* indicates the ONU number, and *n(m)* corresponds to the UNI number in ONU_{*m*}, as reported by ONU. OLT is connected to the packet generator/analyzer via the NNI.

For the purpose of this test, ONUs and OLT are configured to operate in the following configurations.

ONU configurations:

- Authentication: disabled
- Encryption: disabled
- VLAN mode: ONU Tagging VLAN mode
- VLAN based multicast filtering: disabled
- MAC address based multicast filtering: disabled

OLT configurations:

- Authentication: disabled
 - Encryption: disabled
 - VLAN mode: OLT Translation VLAN mode
 - VLAN based multicast filtering: disabled
 - MAC address based multicast filtering: disabled
-

The provisioning for ONUs and OLT may use vendor-specific mechanisms and are outside the scope of this test case.

Authentication and Encryption are disabled for the ONUs and the OLT, and are not tested in this test case. In this test, ONUs and OLT do not perform authentication after the registration process and data transmission between multiple ONUs and OLT is realized as defined in IEEE Std 802.3 without encryption mechanism.

The packet generator is configured to generate flows of Ethernet frames with VLAN tags. The flows of Ethernet frames are shown in Table 4-9 for the downstream direction. Each test flow consists of K packets ($K=2000$). The size of each Ethernet frame is 1000 octets. The order of frames belonging to different flows in the aggregated stream is not specified.

Table 4-9 Test flow in the downstream direction for packet generator

Test flow number	DA	SA	VLAN0-VID ^a
1	0x33-33-00-01-00-00	0x90-82-60-22-22-00	0x4-00

^{a)} The remaining fields in the VLAN0 tag shall use IEEE Std 802.1Q-compliant values (default values).

4.4.1.2. Test description

This test verifies the interoperability for the multicast data transmission from OLT to ONUs, when configured in the specific VLAN modes. Specifically, the following conditions are tested:

- Interoperability for the multicast data transmission when ONUs are operating in the ONU Tagging VLAN mode, and OLT is operating in the OLT Translation VLAN mode, per IEEE Std 1904.1, 7.2.2.1.

4.4.1.3. Test procedure and expected results

Start of Test

Step 1 Initial configuration and provisioning

- 1.1 Connect all equipment as defined in the test setup configuration per 4.4.1.1.
- 1.2 For the OLT, configure the allowed network-side multicast VID value to 0x4-00 and the user-side multicast VID value to 0x8-00, as defined in IEEE Std 1904.1, 7.2.2.1.5.
- 1.3 Reboot ONUs or connect the PON link between ONUs and OLT to allow ONUs to register at OLT.

Step 2 Multicast transmission test

- 2.1 Start the packet analyzer. Start the packet generator in the downstream direction, transmitting the test flow per Table 4-9 across NNI towards each $UNI_{m,n(m)}$ on ONU_m . Allow the packet generator to complete its data trace for all $UNI_{m,n(m)}$.

Expected result 1: *Packet analyzer connected to each $UNI_{m,n(m)}$ on ONU_m shall receive the following number and type of packets for each of frame flows, as defined in Table 4-10:*

— K frames for each of frame flows per $UNI_{m,n(m)}$ of ONU_m .

**Table 4-10— Packets received by the packet analyzer in the downstream direction
 $UNI_{m,n(m)}$ on ONU_m**

Frame flow number	DA	SA	VLAN0-VID
1	0x33-33-00-01-00-00	0x90-82-60-22-22-00	not presented

End of Test

4.5. Group DE: Data Encryption

This test case group covers verification of the interoperability for data encryption process as defined in IEEE Std 1904.1, 11.2.3.

4.5.1. Test case for data encryption, successful IEEE Std 802.1ae-2006

4.5.1.1. Required equipment and test configuration

Test configuration per 3.2.3 shall be used to complete this test case.

ONU_{*m*} with one or more UNIs is connected to the packet generator/analyzer via UNI_{*m,n(m)*}, where *m* indicates the ONU number, and *n(m)* corresponds to the UNI number in ONU_{*m*}, as reported by ONU. The OLT is connected to the packet generator/analyzer via the NNI.

For the purpose of this test, ONU and OLT are configured to operate in the following configurations.

ONU configurations:

- Authentication: disabled
- Encryption: enabled
- VLAN mode: ONU Tagging VLAN mode
- VLAN based multicast filtering: disabled
- MAC address based multicast filtering: disabled

OLT configurations:

- Authentication: disabled
- Encryption: enabled
- VLAN mode: OLT Translation VLAN mode
- VLAN based multicast filtering: disabled
- MAC address based multicast filtering: disabled

In this test case, key exchange is disabled for the ONUs and the OLT, and is not tested. The fixed key and parameters are provisioned for each ONU and OLT. Both upstream and downstream encryptions are enabled. The same key and parameters are used in both directions.

Other configurations for encryption are as follows.

- Security TAG: short
- Confidential offset: disabled

The provisioning for ONU and OLT may use vendor-specific mechanisms and are outside the scope of this test case.

Authentication is disabled for the ONU and the OLT, and is not tested in this test case. In this test, ONU and OLT do not perform authentication after the registration process.

The packet generator is configured to generate flows of Ethernet frames with or without VLAN tags. The flows of Ethernet frames are shown in Table 4-11 for the upstream direction and in Table 4-12 for the downstream direction. Each test flow consists of K packets ($K = 2000$). The size of each Ethernet frame is 1000 octets. The order of frames belonging to different flows in the aggregated stream is not specified.

Table 4-11 Test flow in the upstream direction for packet generator to UNI _{$m,n(m)$} on ONU _{m}

Test flow number	DA	SA ^a	VLAN0-VID
1	0x90-82-60-22-22-00	0x90-82-60-11-11-UNI _{$m,n(m)$}	not present

^{a)} The lowest octet in the MAC is derived from the UNI _{$m,n(m)$} number, represented in a 1 octet-wide format. For example, for UNI _{$m,1$} , the MAC is equal to 0x90-82-60-11-11-01, for UNI _{$m,21$} , the MAC is equal to 0x90-82-60-11-11-15.

Table 4-12 Test flows in the downstream direction for packet generator

Test flow number	DA ^{a,c}	SA	VLAN0-VID ^{a,b}
1	0x90-82-60-11-11-UNI _{$1,n(1)$}	0x90-82-60-22-22-00	0x2-01
2	0x90-82-60-11-11-UNI _{$2,n(2)$}	0x90-82-60-22-22-00	0x2-02
:	:	:	:
M	0x90-82-60-11-11-UNI _{$m,n(m)$}	0x90-82-60-22-22-00	0x2-ONU _{m}

^{a)} m represents ONU number.

^{b)} The remaining fields in the VLAN0 tag shall use IEEE Std 802.1Q-compliant values (default values). The lowest octet in the VLAN0 VID is derived from the ONU number, represented in a 1 octet-wide format.

^{c)} The lowest octet in the MAC is derived from the UNI _{$m,n(m)$} number, represented in a 1 octet-wide format. For example, for UNI _{$m,1$} , the MAC is equal to 0x90-82-60-11-11-01, for UNI _{$m,21$} , the MAC is equal to 0x90-82-60-11-11-15.

4.5.1.2. Test description

This test case covers verification of the interoperability for the successful data encryption and decryption defined in IEEE Std 1904.1 11.2.3.

4.5.1.3. Test procedure and expected results

Start of Test

Step 1 Initial configuration and provisioning

- 1.1 Connect all equipment as defined in the test setup configuration per 4.5.1.1.
- 1.2 Configure the PON-VID value to $0x1-00$ for all ONUs under test, as defined in IEEE Std 1904.1, 7.2.2.1.4. For the OLT, configure the user-side VID value to $0x1-00$ and the network-side VID value to $0x2-ONU_m$ for the ONU_m , as defined in IEEE Std 1904.1, 7.2.2.1.5.
- 1.3 Configure the OLT with the following settings.
 - Secure Association Key (SAK) for all ONU is “IEEE_P19041-pkgB”, UTF-8 string, without a null or other termination, exactly 16-octet length. The hexadecimal value and the transmission bit ordering of SAK are shown in Figure 4-1.

[Hexadecimal]

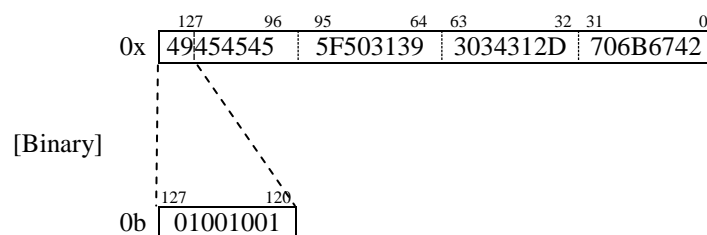

Figure 4-1— Hexadecimal value and transmission bit ordering of SAK

- Association Number (AN) for all ONU is fixed and the value is 0.
 - Secure Channel Identifier (SCI) for ONU_m : The same SCI value is used in the upstream and the downstream channels for the ONU_m . Octets 1 through 6 are OLT MAC address. Octets 7 through 8 vary and depend on the OLT. Thus the OLT operator is expected to notify the ONU_m operator of the entire value of SCI.
- 1.4 Configure the ONU_m with the following setting.

- SAK is “IEEE_P19041-pkgB”, UTF-8 string, without a null or other termination, exact 16-octet length.
 - AN is fixed and the value is zero (0).
 - SCI is the value given by the OLT operator, i.e., the same SCI value is used for the upstream and the downstream channels both at the ONU_m and at the OLT.
- 1.5 Reboot ONUs or connect the PON link between ONUs and the OLT to allow ONUs to register at the OLT.

Step 2 Successful data encryption in upstream direction

- 2.1 Start the packet analyzer. Start the packet generator in the upstream direction, transmitting the test flows per Table 4-11 simultaneously across each UNI_{m,n(m)} on ONU_m towards the NNI on the OLT. Allow the packet generator to complete its data trace for all UNI_{m,n(m)}.

Expected result 1: *Packet analyzer connected to the NNI on the OLT shall receive the following number and type of packets for each of frame flows from each UNI_{m,n(m)} of ONU_m, as defined in Table 4-13:*

- *K frames for each of frame flows per UNI_{m,n(m)} of ONU_m.*

Table 4-13— Packets received by the packet analyzer in the upstream direction

Frame flow number	DA	SA ^{a,c}	VLAN0-VID ^{a,b}
1	0x90-82-60-22-22-00	0x90-82-60-11-11-UNI _{1,m(1)}	0x2-01
2	0x90-82-60-22-22-00	0x90-82-60-11-11-UNI _{2,m(2)}	0x2-02
⋮	⋮	⋮	⋮
<i>M</i>	0x90-82-60-22-22-00	0x90-82-60-11-11-UNI _{m,n(m)}	0x2-ONU _m

^{a)} *m* represents ONU number.

^{b)} The remaining fields in the VLAN0 tag shall use IEEE Std 802.1Q-compliant values (default values). The lowest octet in the VLAN0 VID is derived from the ONU number, represented in a 1 octet-wide format.

^{c)} The lowest octet in the MAC is derived from the UNI_{m,n(m)} number, represented in a 1 octet-wide format. For example, for UNI_{m,1}, the MAC is equal to 0x90-82-60-11-11-01, for UNI_{m,21}, the MAC is equal to 0x90-82-60-11-11-15.

Step 3 Successful data encryption in downstream direction

- 3.1 Start the packet analyzer. Start the packet generator in the downstream direction, transmitting the test flow per Table 4-12 across the NNI towards each $UNI_{m,n(m)}$ on ONU_m . Allow the packet generator to complete its data trace for all $UNI_{m,n(m)}$.

Expected result 2: *Packet analyzer connected to each $UNI_{m,n(m)}$ on ONU_m shall receive the following number and type of packets for each of frame flows, as defined in Table 4-14:*

— K frames for each of frame flows per $UNI_{m,n(m)}$ on ONU_m .

Table 4-14— Packets received by the packet analyzer in the downstream direction from $UNI_{m,n(m)}$ on ONU_m

Frame flow number	DA ^a	SA	VLAN0-VID
1	0x90-82-60-11-11- $UNI_{m,n(m)}$	0x90-82-60-22-22-00	not present

^{a)} The lowest octet in the MAC is derived from the $UNI_{m,n(m)}$ number, represented in a 1 octet-wide format. For example, for $UNI_{m,1}$, the MAC is equal to 0x90-82-60-11-11-01, for $UNI_{m,21}$, the MAC is equal to 0x90-82-60-11-11-15.

End of Test

4.6. Group MG: Management

This test case group covers verification of the interoperability for eOAM management as defined in IEEE Std 1904.1, 13.1, 13.3, and 14.3.

4.6.1. Test case for management, successful eOAM sequence and message format

4.6.1.1. Required equipment and test configuration

Test configuration per 3.2.3 shall be used to complete this test case. If PON Protocol Analyzer is available, test configuration per 3.2.4 may be used.

In this test case, ONUs shall operate in ReturnCode mode, as defined in IEEE Std 1904.1, 13.3.3.4. Each eOAMPDU shall contain no more than one TLV, i.e., does not contain *Object_ID* TLV.

4.6.1.2. Test description

This test verifies the interoperability for the eOAM sequence and message format between OLT and ONUs. Specifically, the following conditions are tested:

- To get *ONU System Info* TLV (0xB7/0x00-40), as defined in IEEE Std 1904.1, 14.3.1.37, using *GetRequest/GetResponse* eOAMPDU,
- To set *VLAN Mode* TLV (0xB7/0x00-0B), as defined in IEEE Std 1904.1, 14.3.1.5, using *SetRequest/SetResponse* eOAMPDU, and
- To set *PON-VID Value* TLV (0xB7/0x00-15), as defined in IEEE Std 1904.1, 14.3.1.13, using *SetRequest/SetResponse* eOAMPDU.

4.6.1.3. Test procedure and expected results

Start of Test

Step 1 Initial configuration and provisioning

- 1.1 Connect all equipment as defined in the test setup configuration per 4.6.1.1.
- 1.2 Reboot ONUs or connect the PON link between ONUs and OLT to allow ONUs to register at OLT.

Step 2 eOAM sequence and message format test, *GetRequest/GetResponse* eOAMPDU

- 2.1 Configure the OLT to send the *GetRequest* eOAMPDU to get *ONU System Info* TLV (0xB7/0x00-40) to a given ONU.

Expected result 1: *The OLT shall transmit GetRequest eOAMPDU.*

The verification of this step may use vendor-specific mechanisms or PON Protocol Analyzer and is outside the scope of this test case. Also, at the following expected results, the verification methodology is outside the scope of this test case.

- 2.2 Wait at least 1 second.

Expected result 2: *The ONU shall transmit GetResponse eOAMPDU including ONU System Info TLV without any error codes. The value of TLV shall be the same as the ONU responds.*

- 2.3 Repeat step 2.1 to 2.2 for each ONU.

Step 3 eOAM sequence and message format test, *SetRequest/SetResponse* eOAMPDU

- 3.1 Configure the OLT to send the *SetRequest* eOAMPDU to set *VLAN Mode* TLV (0xB7/0x00-0B) to a given ONU.

Expected result 3: *The OLT shall transmit SetRequest eOAMPDU.*

- 3.2 Wait at least 1 second.

Expected result 4: *The ONU shall transmit SetResponse eOAMPDU without any error codes.*

- 3.3 Configure the OLT to send the *SetRequest* eOAMPDU to set *PON-VID Value* TLV (0xB7/0x00-15) to the ONU.

Expected result 5: *The OLT shall transmit SetRequest eOAMPDU.*

- 3.4 Wait at least 1 second.

Expected result 6: *The ONU shall transmit SetResponse eOAMPDU without any error codes.*

- 3.5 Repeat step 3.1 to 3.4 for each ONU.

End of Test

4.7. Judgement

Device under test will be confirmed as successfully passed each interoperability test item when each tested result has been met with each Expected result defined in the subclause 4.2 through 4.6.

4.8. Test result

At each test step which describes expected result in the test case, the tested result shall be recorded in the Appendix Optical Access Interoperability Test Result attached in the end of this document. It is requested to record observed failures and errors while running the test with its details, such as phenomenon, situation, causes, and required actions etc., in the Appendix.

Test configurations shall be recorded in the attached configuration sheet which presents combinations for OLT and ONUs used in the form in the attachment.

If an examinee(s) wants to request a retest, indicate the request in the Note in the Appendix.

5. Use of test result

5.1. Usage

The results of the interoperability test submitted by participants will be collected and compiled by the HATS Conference, Optical Access TILC. The compiled recorded test result will be used to improve the interoperability test; efficiency of the tests, the test procedures, the methods, the operation, etc.,

The organized results, in principle, may be published under the agreement of participants.

If any request and/or suggestion for this test guideline arise while conducting the interoperability test, they may be submitted at any time to HATS Conference, Optical Access TILC, which will deliberate on whether to accept them.

5.2. Feedback to standards

Any issue(s) found in the contexts of the normative reference and any related standards during this interoperability test, required feedback will be considered according to the necessity. The conclusion will be utilized in the future standardization efforts.

Appendix Optical Access Interoperability Test Result

Recorder

OLT		ONU	
Name		Name	
Affiliation		Affiliation	
TEL		TEL	
FAX		FAX	

Date and Time: [_____(YYYY/MM/DD) From ____:____ To ____:____ (HH:MM)]

Testing Site: [_____]

Test Configuration [_____]

OLT: [Manufacture: _____ Model No: _____]

ONU: [Manufacture: _____ Model No: _____]

Group	Step	Sub-Step	IEEE Std 1904.1 PICS List	Pass/Fail	Note
4.2 DCD	1	1.1	NA	NA	
		1.2	NA	NA	
	2	2.1	BU-DCD0 BU-DCD1 BT-DCD0 BT-DCD1		
4.3.1 UVM/TVM	1	1.1	NA	NA	
		1.2	NA	NA	
		1.3	NA	NA	
	2	2.1	BU-UVM3c BT-TVM4b		
	3	3.1	BU-UVM3a BT-TVM4a		
4.3.2 UVM/TVM with multiple ONUs	1	1.1	NA	NA	
		1.2	NA	NA	
		1.3	NA	NA	
	2	2.1	BU-UVM3c BT-TVM4b		
	3	3.1	BU-UVM3a BT-TVM4a		
4.4 MC	1	1.1	NA	NA	
		1.2	NA	NA	
		1.3	NA	NA	
	2	2.1	BU-UVM3c BT-TVM4b		

Group	Step	Sub-Step	IEEE Std 1904.1 PICS List	Pass/Fail	Note
4.5 DE	1	1.1	NA	NA	
		1.2	NA	NA	
		1.3	NA	NA	
		1.4	NA	NA	
		1.5	NA	NA	
	2	2.1	BU-DE0 BU-DE1 BU-DE3 BT-DE0 BT-DE1 BT-DE3		
			BU-DE0 BU-DE1 BU-DE3 BT-DE0 BT-DE1 BT-DE3		
	3	3.1	BU-DE0 BU-DE1 BU-DE3 BT-DE0 BT-DE1 BT-DE3		

Group	Step	Sub-Step	IEEE Std 1904.1 PICS List	Pass/Fail	Note
4.6 MG	1	1.1	NA	NA	
		1.2	NA	NA	
	2	2.1	BT-MG0 BT-MG1 BT-MG2 BT-MG3 BT-MG4 BT-MG7 BT-ME38		
			BU-MG0 BU-MG1 BU-MG2 BU-MG3a BU-MG4 BU-MG5 BU-MG6 BU-MG7 BU-MG8a BU-MG8b BU-ME38		
			BU-MG0 BU-MG1 BU-MG2 BU-MG3a BU-MG4 BU-MG5 BU-MG6 BU-MG7 BU-MG8a BU-MG8b BU-ME38		
			BU-MG0 BU-MG1 BU-MG2 BU-MG3a BU-MG4 BU-MG5 BU-MG6 BU-MG7 BU-MG8a BU-MG8b BU-ME38		

Group	Step	Sub-Step	IEEE Std 1904.1 PICS List	Pass/Fail	Note
		2.3	BT-MG0 BT-MG1 BT-MG2 BT-MG3 BT-MG4 BT-MG7 BT-ME38 BU-MG0 BU-MG1 BU-MG2 BU-MG3a BU-MG4 BU-MG5 BU-MG6 BU-MG7 BU-MG8a BU-MG8b BU-ME38		
	3	3.1	BT-MG0 BT-MG1 BT-MG2 BT-MG3 BT-MG5 BT-MG9 BT-ME6		
		3.2	BU-MG0 BU-MG1 BU-MG2 BU-MG3a BU-MG4 BU-MG5 BU-MG6 BU-MG10a BU-MG10b BU-MG10c BU-MG26a BU-MG26b BU-MG26c BU-ME6		
		3.3	BT-MG0 BT-MG1 BT-MG2 BT-MG3 BT-MG5 BT-MG9 BT-ME14		

Group	Step	Sub-Step	IEEE Std 1904.1 PICS List	Pass/Fail	Note
		3.4	BU-MG0 BU-MG1 BU-MG2 BU-MG3a BU-MG4 BU-MG5 BU-MG6 BU-MG10a BU-MG10b BU-MG10c BU-MG26a BU-MG26b BU-MG26c BU-ME14		
		3.5	BT-MG0 BT-MG1 BT-MG2 BT-MG3 BT-MG5 BT-MG9 BT-ME6 BT-ME14 BU-MG0 BU-MG1 BU-MG2 BU-MG3a BU-MG4 BU-MG5 BU-MG6 BU-MG10a BU-MG10b BU-MG10c BU-MG26a BU-MG26b BU-MG26c BU-ME6 BU-ME14		

Note

Description for Observed Issues

.....

.....

.....

.....

Attachment Test Configurations

[Test Configuration #1]

OLT: _____

ONUs: _____

[Test Configuration #2]

OLT: _____

ONUs: _____

[Test Configuration #3]

OLT: _____

ONUs: _____

[Test Configuration #4]

OLT: _____

ONUs: _____

Note: Add a sheet(s) for the test configuration when filled up.
